

## 7. Timing Belt

### A: REPLACEMENT

#### 1. SOHC MODEL

- 1) Remove the radiator fan and air conditioner fan. <Ref. to CO(H4SO)-22, Radiator Main Fan and Fan Motor.>, <Ref. to CO(H4SO)-23, Radiator Sub Fan and Fan Motor.>
- 2) Shield the radiator from any damage using cardboard and blanket.
- 3) Remove the V-belt cover.

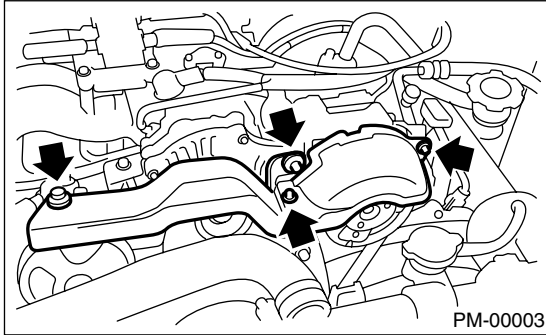

- 4) Remove the V-belts. <Ref. to ME(H4SO)-40, V-belt.>
- 5) Remove the air conditioning compressor drive belt tensioner.
- 6) To lock the crankshaft, use ST. Remove the pulley bolt.

ST 499977100 CRANKSHAFT PULLEY WRENCH

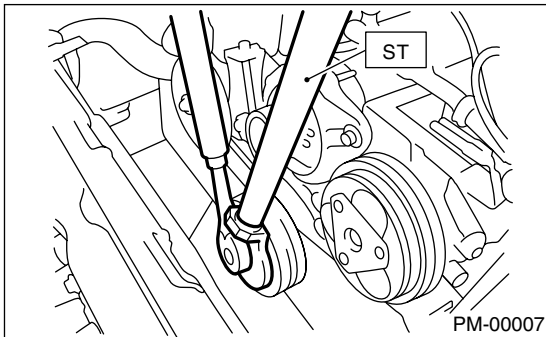

- 7) Remove the crankshaft pulley.
- 8) Remove the left side belt cover.
- 9) Remove the front timing belt cover.

- 10) Remove the timing belt guide. (MT model)

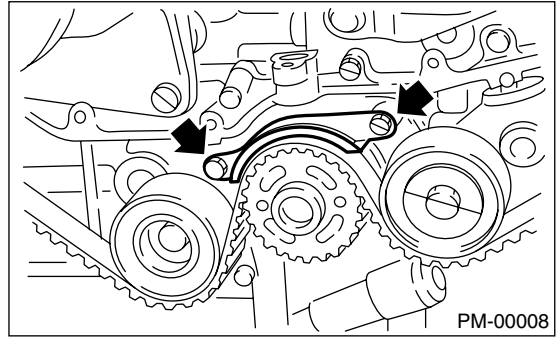

- 11) Turn the crankshaft and align alignment marks on crankshaft, and right and left camshaft sprockets with notches of belt cover and cylinder block. ST 499987500 CRANKSHAFT SOCKET

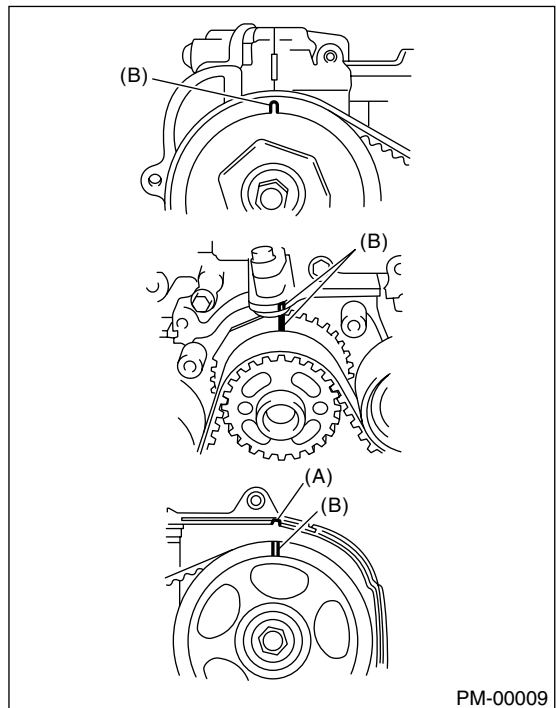

- (A) Notch  
(B) Alignment mark

- 12) Remove the belt idler.
- 13) Remove the belt idler (No. 2).

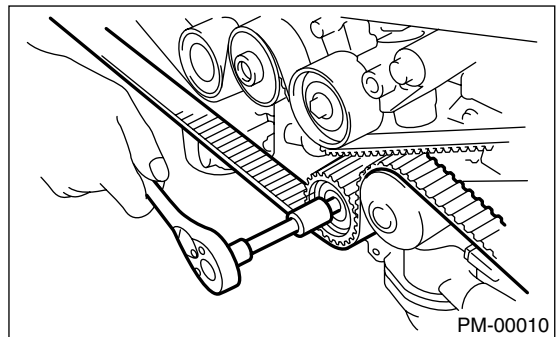

- 14) Remove the timing belt.

# TIMING BELT

## PERIODIC MAINTENANCE SERVICES

15) Remove the automatic belt tension adjuster assembly.

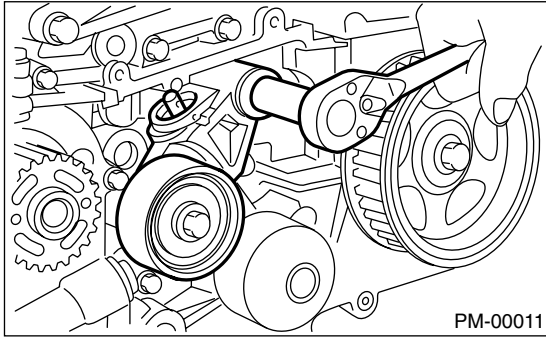

16) Install in the reverse order of removal. <Ref. to ME(H4SO)-46, INSTALLATION, Timing Belt Assembly.>

## 2. DOHC MODEL

1) Remove the radiator fan and air conditioner fan. <Ref. to CO(H4DOTC)-27, Radiator Main Fan and Fan Motor.>, <Ref. to CO(H4DOTC)-29, Radiator Sub Fan and Fan Motor.>

2) Protect the radiator with cardboard and blanket.  
3) Remove the V-belts. <Ref. to ME(H4DOTC)-41, V-belt.>

4) Remove the air conditioning compressor drive belt tensioner.

5) Remove the pulley bolt. To lock the crankshaft use ST.

Except for STi model:

ST 499977400 CRANKSHAFT PULLEY WRENCH

STi model:

ST 499977100 CRANKSHAFT PULLEY WRENCH

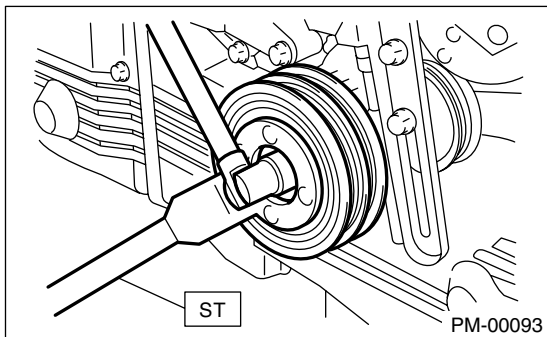

6) Remove the crankshaft pulley.

7) Remove the air conditioning compressor drive belt tensioner.

8) Remove the belt cover (LH).

9) Remove the belt cover (RH).

10) Remove the front belt cover.

11) Remove the timing belt guide. (MT model)

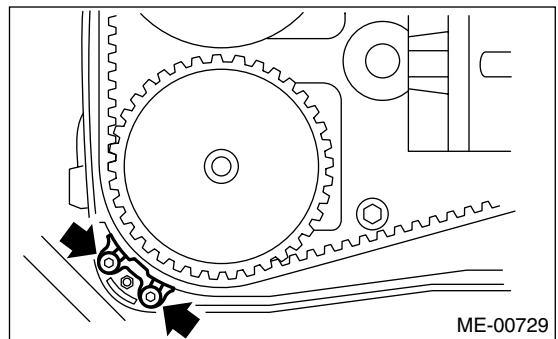
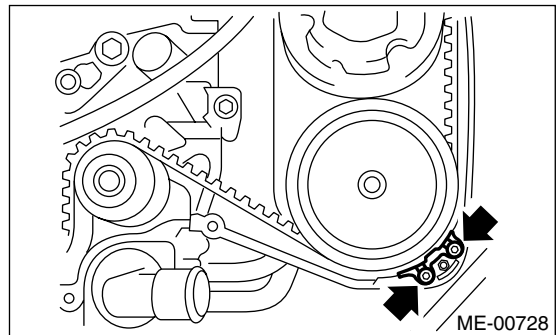
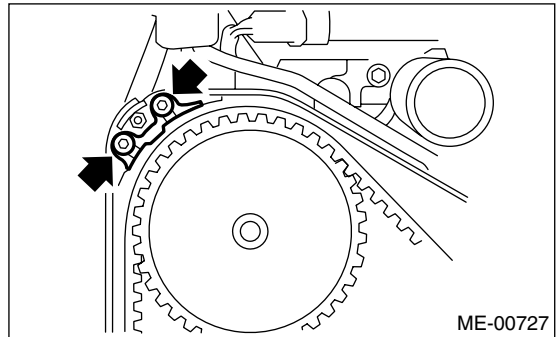
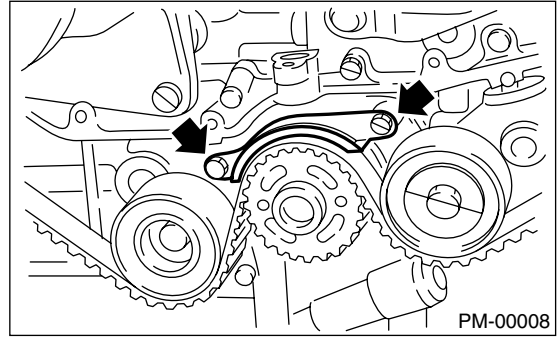

12) Turn the crankshaft and align alignment marks on crankshaft, and right and left camshaft sprockets with notches of belt cover and cylinder block. To turn the crankshaft, use ST.

ST 499987500 CRANKSHAFT SOCKET

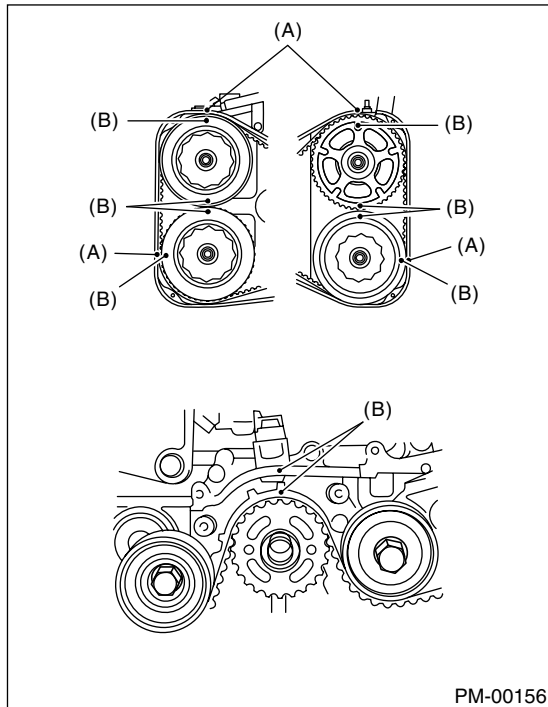

- (A) Notch
- (B) Alignment mark

13) Remove the belt idler.

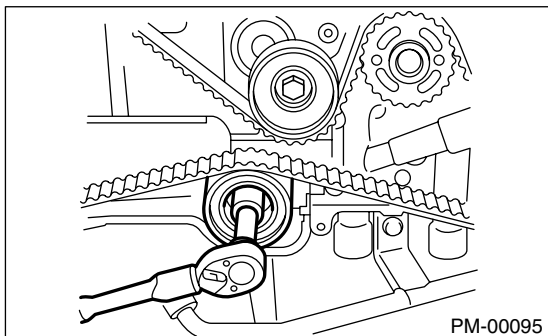

14) Remove the timing belt.

15) Remove the automatic belt tension adjuster assembly.

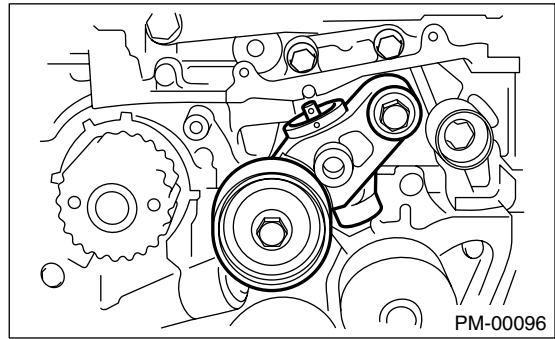

16) Install in the reverse order of removal. <Ref. to ME(H4DOTC)-46, Timing Belt Assembly.>

**CAUTION:**

**When installing the timing belt, be sure to align all alignment marks on the belt with corresponding marks on the sprockets. If incorrectly installed, interference between pistons and valves may occur.**

**B: INSPECTION**

**1. SOHC MODEL**

- 1) Remove the front timing belt cover and timing belt cover (LH).
- 2) While cranking the engine at least four rotations, check the timing belt back surface for cracks or damage. Replace the faulty timing belt as needed.
- 3) Measure the timing belt width W. If it is less than 27 mm (1.06 in), check idlers, tensioner, water pump pulley and cam sprocket to determine idler alignment (squareness). Replace the worn timing belt.

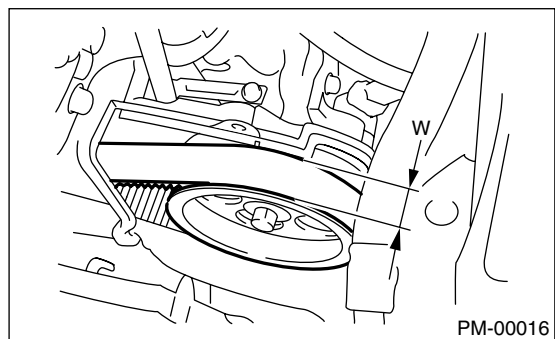

4) Install the front timing belt cover and timing belt cover (LH).

# TIMING BELT

## PERIODIC MAINTENANCE SERVICES

---

### 2. DOHC MODEL

- 1) Remove the timing belt cover (LH).
- 2) While cranking the engine at least four rotations, check the timing belt back surface for cracks or damage. Replace the faulty timing belt as needed.
- 3) Measure the timing belt width  $W$ . If it is less than 30 mm (1.18 in), check idlers, tensioner, water pump pulley and cam sprocket to determine idler alignment (squareness). Replace the worn timing belt.
- 4) Install the timing belt cover (LH).

