

15.ATF

A: INSPECTION

CAUTION:

The level of ATF varies with fluid temperature. Pay attention to the fluid temperature when checking ATF level.

1) Raise the ATF temperature by driving a distance of 5 to 10 km (3 to 6 miles). Otherwise, idle the engine to raise ATF temperature to 70 — 80°C (158 — 176°F) on Subaru Select Monitor. <Ref. to 4AT-21, READ CURRENT DATA, OPERATION, Subaru Select Monitor.>

2) Make sure the vehicle is level.

3) After selecting all positions (P, R, N, D, 3, 2, 1), set the select lever in “P” range. Measure the ATF level with the engine idling for one or two minutes.

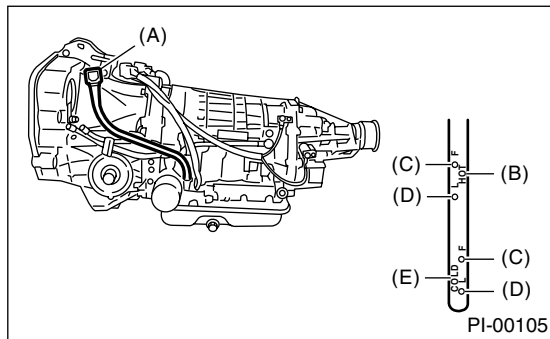

- (A) Level gauge
- (B) Hot side
- (C) Upper level
- (D) Lower level
- (E) Cold side

4) Make sure that ATF level is above the center of upper and lower marks.

NOTE:

When the transmission is hot, the level should be above the center of upper and lower marks, and when it is cold, the level should be found below the center of these two marks.

5) If the ATF level is below the center between upper and lower marks, add the recommended ATF until the ATF level is found above the center between upper and lower marks.

CAUTION:

- Use care not to exceed the upper limit level.
- Remember that the addition of ATF to the upper limit mark when the transmission is cold will result in overfilling of ATF, causing a transmission failure.

6) Check ATF level after raising ATF temperature to 70 — 80°C (158 — 176°F) by running the vehicle or by idling the engine again.

7) Check the ATF for leaks.

Check for leaks in the transmission. If there are leaks, it is necessary to repair or replace gasket, oil seals, plugs or other parts.

B: REPLACEMENT

1. AUTOMATIC TRANSMISSION FLUID

1) Drain the ATF (Automatic Transmission Fluid) by removing drain plug.

NOTE:

Before starting work, cool off the ATF well.

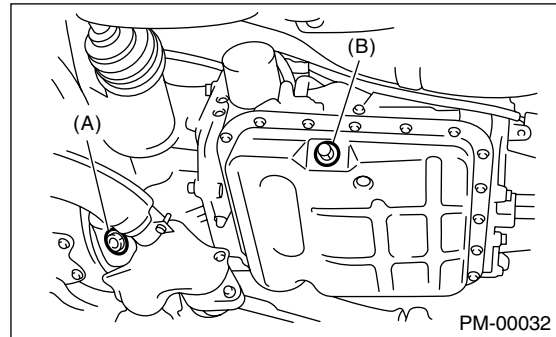

- (A) Front differential drain plug
- (B) ATF drain plug

2) Replace the gasket with a new one, and then tighten the specified torque.

Tightening torque:

25 N·m (2.55 kgf-m, 18.4 ft-lb)

3) Fill ATF up to the middle of the “COLD” side on level gauge by using the gauge hole.

Recommended fluid:

Dexron III type automatic transmission fluid

Fluid capacity:

Fill the same amount drained from ATF drain plug hole.

4) Check the ATF level. <Ref. to PM-24, INSPECTION, ATF.>

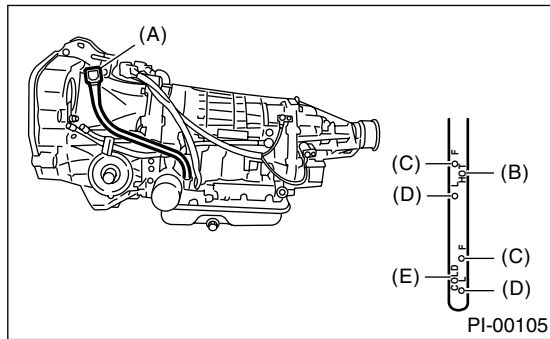

- (A) Level gauge
- (B) Hot side
- (C) Upper level
- (D) Lower level
- (E) Cold side

2. ATF FILTER

NOTE:

ATF filter is a maintenance free part. ATF filter needs replacement, when it has physically damaged or ATF leaked.

For the replacement procedures of the ATF filter:
<Ref. to 4AT-66, ATF Filter.>